

Key Features Overview

- 3 x 3 mm² Active Area, 25 μm Microcells
- High Photo Detection Efficiency
- Excellent Timing Properties
- Replacement for PMTs, APDs and PIN Diodes
- Low Voltage Operation (typ. about 30 V)
- Cost Efficient and Robust (MSL1 approved)

Application Examples

- Single Photon Counting
- Scintillator Readout
- Medical Imaging (PET, SPECT)
- Photon Timestamping
- Handheld and Mobile Devices
- Hazard & Threat Detection
- Biophotonics
- High Energy Physics & Research
- Analytical Instrumentation

Spectral Response

Photo Detection Efficiency at 5 V Overvoltage

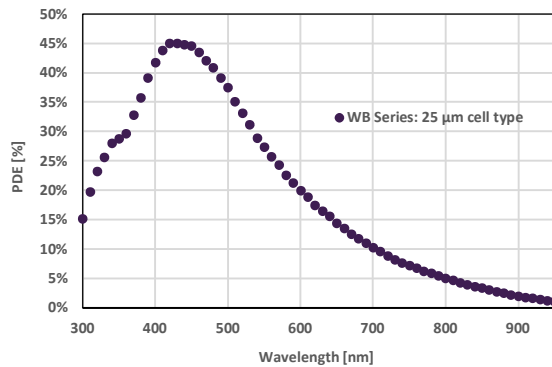
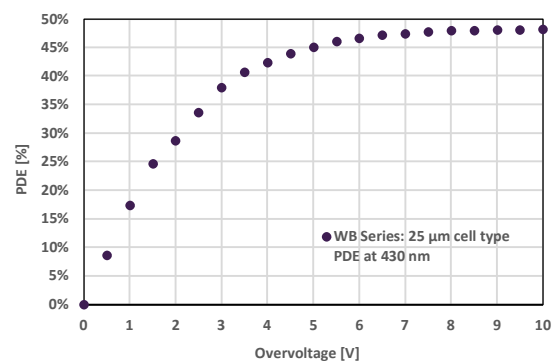

Photo Detection Efficiency vs. Overvoltage at 21°C



General Parameters and Order Information

SiPM Type	Active Area [mm ²]	Microcell Size [μm]	No. of Microcells	Dimensions [mm ³]	Order-Code
PM3325-WB	3.0 x 3.0	25	13920	3.315 x 3.315 x 0.595	PM3325-WB-D0

Main Characteristics

Parameter	Typ.	Unit
Breakdown Voltage (V _{BD}) at 21°C	min. 24.0, max. 25.0	V
Breakdown Voltage Variation per Reel	±0.125	V
Recommended Overvoltage (V _{OV})	2.0 – 5.0 (max. 6.0)	V
Temperature Dependency of V _{BD}	22.0	mV/K
Temperature Dependency of Gain	0.3% @ 5.0 V _{OV}	1/K
Operating Temperature Range	-40 to + 60	°C
Reliability Classification	MSL1	
Index of Refraction of Glass Entrance Window	1.52 @ 430 nm	

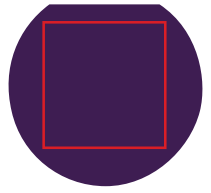

Electrical and Optical Characteristics at 21°C

Parameter	Typ. @ 2.5 V _{OV}	Typ. @ 5.0 V _{OV}	Unit
Photo Detection Efficiency at 430 nm	31	45	%
Dark Count Rate	50	125	kHz/mm ²
Dark Current	0.15 (max. 0.2)	0.7 (max. 1.0)	μA
Gain	0.87	1.74	x 10 ⁶
Crosstalk Probability*	12	26	%
Afterpulsing Probability	1	5	%
Terminal Capacitance	1		nF
Recovery Time τ	33 (at 1 Ω load), 80 (at 50 Ω load)		ns
Signal Rise Time	110		ps

* Including delayed crosstalk with a probability < 0.1%

Mechanical Specifications

Dimensions and Recommended Footprint*

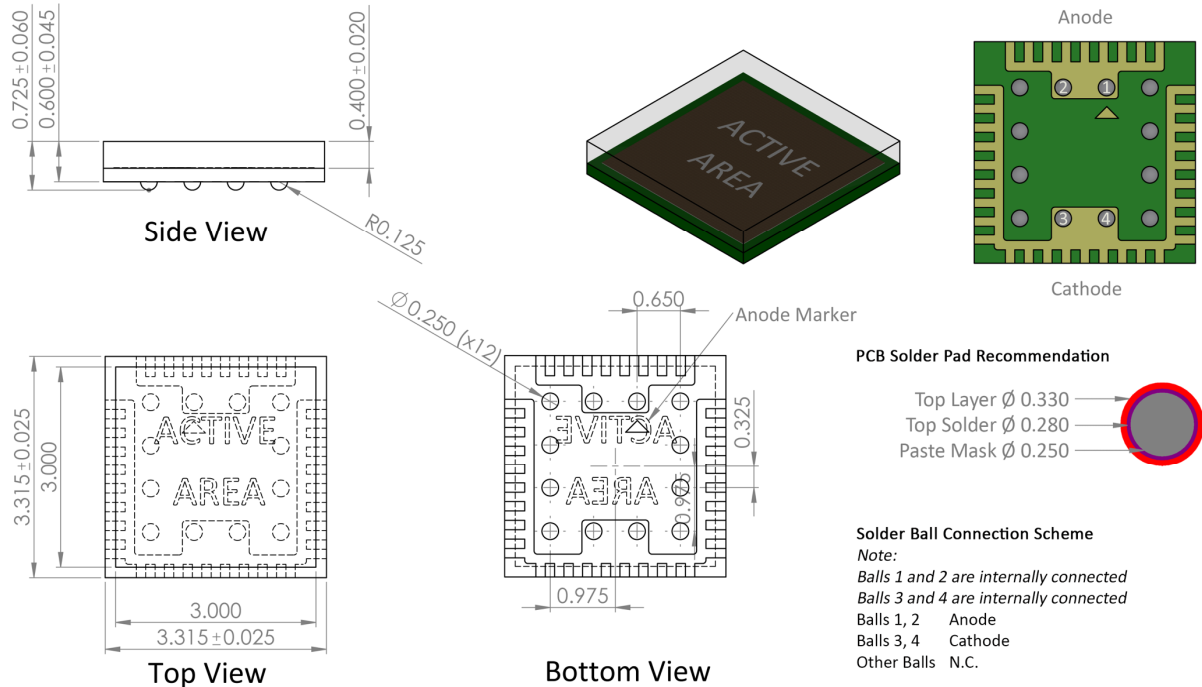

* Footprint and 3D model are available for download at www.ketek.net/sipm-downloads/

PM3325-WB preassembled on PCB with Pins (available for Evaluation Purposes)*

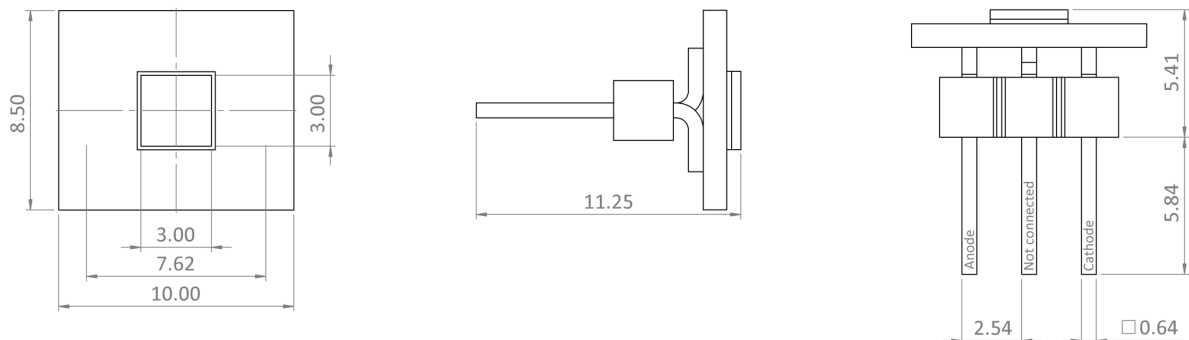

* Mates e.g. with Preci-Dip 801-87-003-10-001101

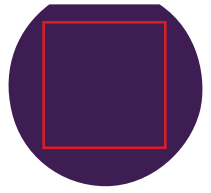

Typical Performance Characteristics

Temperature Coefficient of the Breakdown Voltage

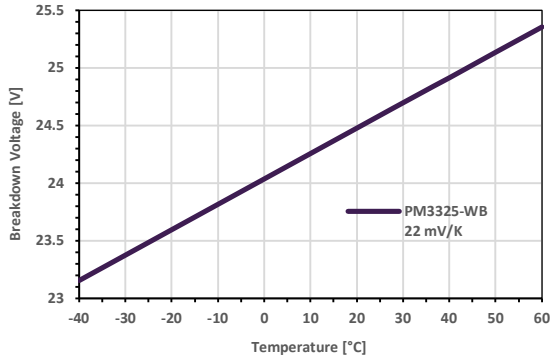

Temperature Coefficient of the Gain

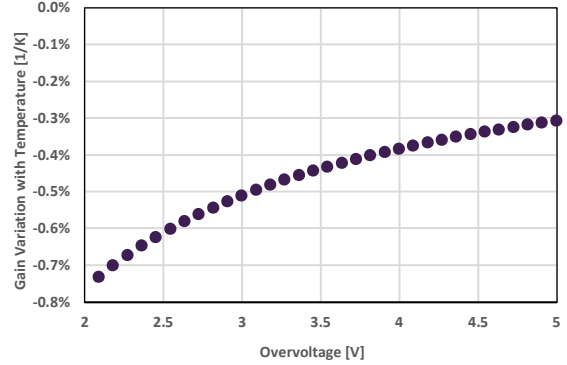

Linearity at 430 nm

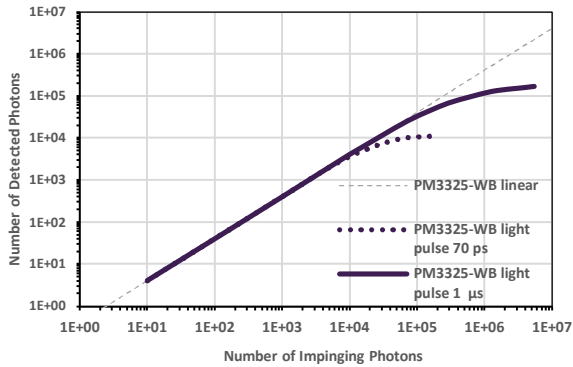

Gain of WB Series

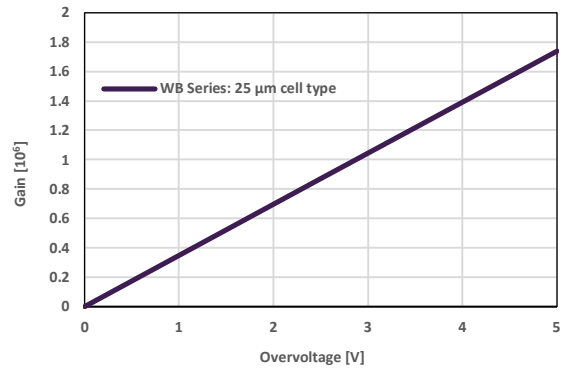

Dark Count Rate at 21°C

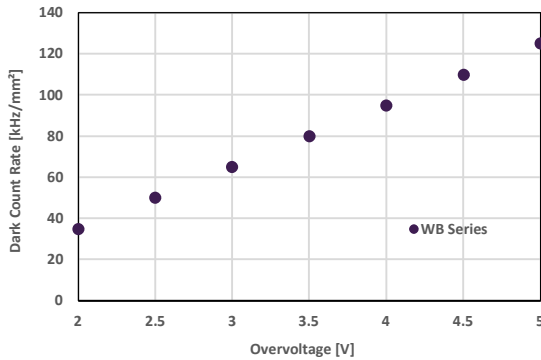

Dark Count Rate vs. Temperature

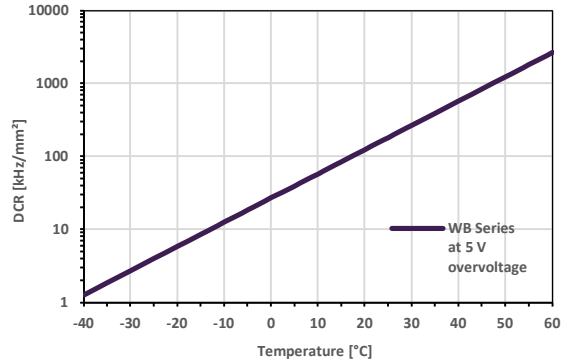

Direct Optical Crosstalk

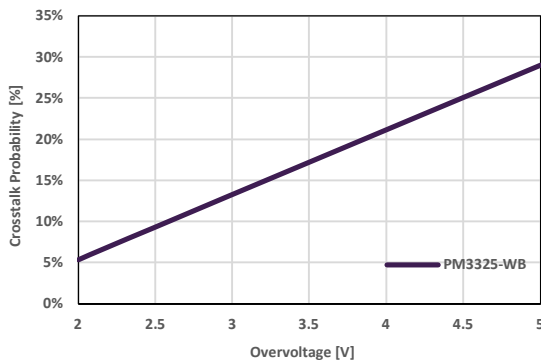

Delayed Optical Crosstalk

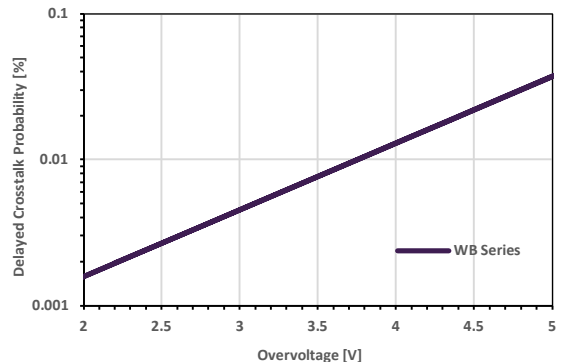

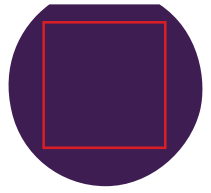

Afterpulsing Probability

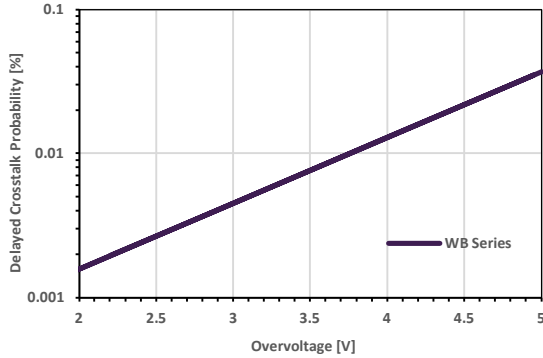

Pulse Shape at 1 Ω Load, Single Photon Spectrum

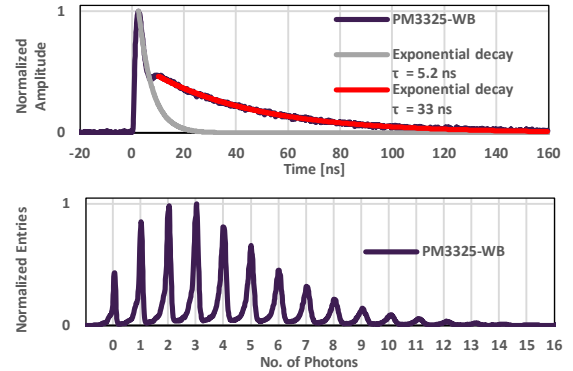

Assembly Specifications

Tape and Reel

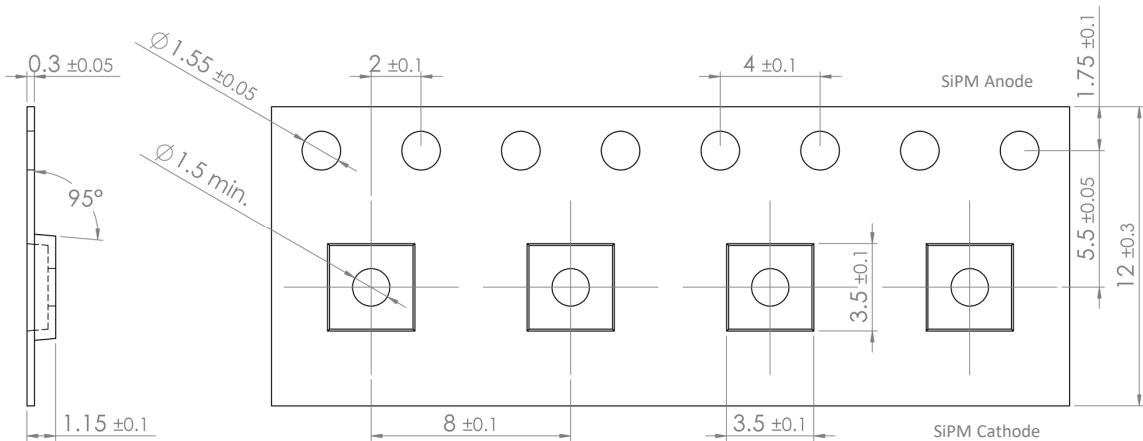

Recommended Reflow Solder Profile*

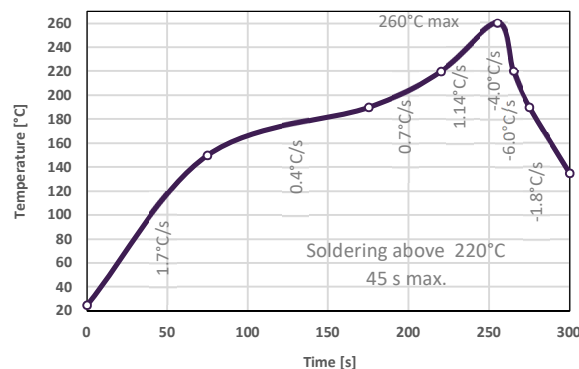

* Lead-free no-clean solder paste type 4 is recommended, e.g. SAC305 ROL0 Nihon Handa PF305-118
SMD stencil thickness of 80 μ m is recommended

Revision History

Revision and Date	Changes
Rev. 2020-A April 2020	Updated design and layout Updated table "Performance Overview at 21°C" and corresponding plots <ul style="list-style-type: none"> - Afterpulsing Probability (specified at 2.5 V and 5 V overvoltage) - Recovery Time (specified at 1 Ω and 50 Ω load) - Signal Rise Time (specified more precisely)
Rev. 2019-C July 2019	Updated table "Main Characteristics" and corresponding plots Updated table "Performance Overview at 21°C" corresponding plots Updated "Recommended Reflow Solder Profile" Updated "Tape and Reel Specifications" with number of pcs per reel
Rev. 2019-B June 2019	Added part orientation to "Tape and Reel Specifications"
Rev. 2019-A January 2019	Updated design and layout Updated "Technical Drawing and Recommended Footprint" Added performance plots for all key parameters
Rev. 2018-A December 2018	Added "Tape and Reel Specifications"
Rev. 2017-B April 2017	Updated table "Performance Overview at 21°C" Added "Recommended Reflow Solder Profile"
Rev. 2017-A February 2017	Added "PM33xx-WB preassembled on PCB with Pins (available for Evaluation Purposes)"
Rev. 2016-A October 2016	Initial Release

Important Notice

KETEK reserves the right to make changes without further notice to any products herein. KETEK makes no warranty, representation or guarantee regarding the suitability of its products for any particular purpose, nor does KETEK assume any liability arising out of the application or use of any product or circuit, and specifically disclaims any and all liability, including without limitation special, consequential or incidental damages. "Typical" parameters which may be provided in KETEK data sheets and/or specifications can and do vary in different applications and actual performance may vary over time. All operating parameters, including "Typical" must be validated for each customer application by customer's technical experts. KETEK does not convey any license under its patent rights nor the rights of others. KETEK products are not designed, intended, or authorized for use as components in applications in which the failure of the KETEK product could create a situation where personal injury or death may occur. Should Buyer purchase or use KETEK products for any such unintended or unauthorized application, Buyer shall indemnify and hold KETEK and its officers, employees, subsidiaries, affiliates, and distributors harmless against all claims, costs, damages, and expenses, and reasonable attorney fees arising out of, directly or indirectly, any claim of personal injury or death associated with such unintended or unauthorized use, even if such claim alleges that KETEK was negligent regarding the design or manufacture of the part.